

5<sup>TH</sup> TIME  
(EXACTLY AS BEFORE.)

# TOMBEAU/Ω POINT



GHOSTLY THROUGHOUT — AS IF HEARD FROM A DISTANCE, DREAMLIKE

(Loco) 

$\downarrow = \uparrow$  (L=54)

(ABRUPT STOP: NO PAUSE)

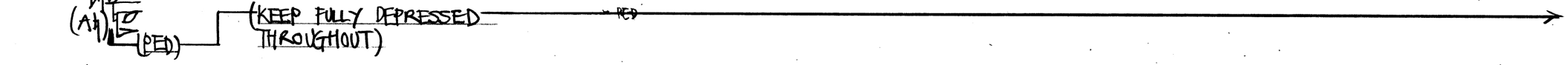
(A4) (PED) (KEEP FULLY DEPRESSED THROUGHOUT)

(PED) (UC)



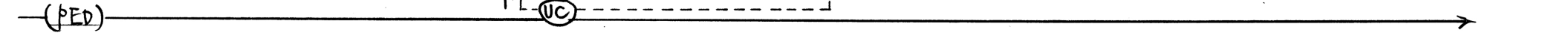
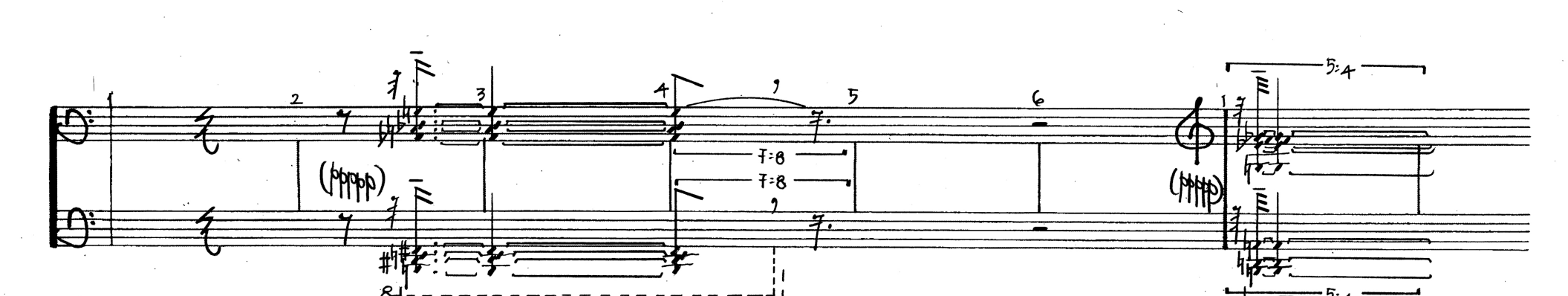

(ppppp)

F#8

F#8

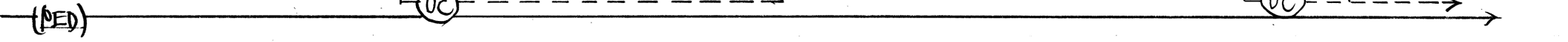
(UC) 5:4



Handwritten musical score for the first system. It consists of two staves. The upper staff begins with a treble clef and a key signature of two sharps (F# and C#). The lower staff begins with a bass clef and the same key signature. The music is marked with various time signatures: 5:4, 3, 4, 5, 6, and 2. There are several notes, some with slurs, and rests. Performance markings include *(ppppp)* in the lower staff, a circled *UC* with a dashed line, and a circled *(PED)* at the beginning. An arrow points to the right below the staves.

Handwritten musical score for the second system. It consists of two staves. The upper staff begins with a treble clef and a key signature of two sharps (F# and C#). The lower staff begins with a bass clef and the same key signature. The music is marked with various time signatures: 5:4, 3:2, 5:4, 7:8, and 3. There are several notes, some with slurs, and rests. Performance markings include *(ppppp)* in the lower staff, a circled *UC* with a dashed line, and a circled *(PED)* at the beginning. A key signature change is indicated as *A/C# F# G#*. The system concludes with the word *ATTACCA* and the number *1*. An asterisk is placed at the end of the system.



SOTTO VOCE & GLASSY

(EVENLY)

1

pppp

p

3:2 3:2 3:2 3:2 3:2 3:2 3:2 3:2 (e. sim.)

3p → (PED)

pppp

3:2 3:2

3p → (PED)

pppp

8

(Loco)

pppp

(Loco)

8

3p → (PED)

3:2



$\downarrow = 48$  (GHOSTLY)

3/4

Handwritten musical score for the first system. It consists of two staves. The top staff has a treble clef and a key signature of one sharp (F#). The bottom staff has a bass clef. The music is in 3/4 time. The first staff begins with a dynamic marking of *ppp* and a hairpin crescendo. There are several measures of music with various rhythmic values. Brackets below the staves indicate time signatures: 5:4, 7:8, 3:2, and 5:4. A circled number '8' is written above the first staff. At the bottom left, there is a circled '1' and a note '1/2 p'.

SAME TEMPO  
(SUBTERRANEAN)

5

Handwritten musical score for the second system. It consists of two staves. The top staff has a treble clef and a key signature of one sharp (F#). The bottom staff has a bass clef. The music is in 5/4 time. The first staff begins with a dynamic marking of *mf* and a hairpin crescendo. There are several measures of music with various rhythmic values. Brackets below the staves indicate time signatures: 5:4, 5:4, 5:4, 3:2, and 3:2. A circled number '8' is written above the first staff. The word '(loco)' is written above the first staff. At the bottom left, there is a circled '1' and a note '1/2 p'. At the bottom right, there is a circled 'UC' and a dashed line with an arrow pointing right.

Handwritten musical score for the third system. It consists of two staves. The top staff has a treble clef and a key signature of one sharp (F#). The bottom staff has a bass clef. The music is in 5/4 time. The first staff begins with a dynamic marking of *pppp*. There are several measures of music with various rhythmic values. Brackets below the staves indicate time signatures: 3:2, 3:2, 5:4, and 5:4. At the bottom left, there is a circled 'UC' and a note '(PED)'. At the bottom right, there is a circled 'UC' and a dashed line with an arrow pointing right.

6

$\downarrow = 46$

pp

p

pp

mfz (poco)

p

pp

ppp

3p

5=4

5=4

7=6

7=6

5=4

L(PED)

3p

$\downarrow = \%_6$  (DELICATELY!)

7

Handwritten musical score for the first system. It consists of two staves. The upper staff contains a melodic line with various accidentals and slurs. The lower staff contains a more complex rhythmic accompaniment with many beamed notes. Dynamic markings include *ppp* at the beginning and *mf* later on. A large slur covers the entire system. Below the staves, there are performance instructions: "(PED) (FULL)" on the left and " $\frac{1}{2}p$ " on the right.

(SAME TEMPO)

Handwritten musical score for the second system. It consists of two staves. The notation continues with complex rhythmic patterns and slurs. Dynamic markings include *(mf)* and *ppp*. There are several instances of "5:4" and "3:2" ratios written below the notes. A circled "VC" is at the end of the system. Below the staves, there are performance instructions: " $\frac{1}{2}p$ " on the left and "(PED)" on the right.

Handwritten musical score for the third system. It consists of two staves. The notation continues with complex rhythmic patterns and slurs. Dynamic markings include *pppp* and *pp*. There are several instances of "5:4" and "3:2" ratios written below the notes. A circled "VC" is at the beginning of the system. Below the staves, there are performance instructions: "(PED)" on the left and "(cf)" on the right.

$\text{♩} = 60$

DELICATELY

8

Handwritten musical score for the first system. It consists of two staves: a treble clef staff on top and a bass clef staff on the bottom. The treble staff begins with a whole note chord, followed by a series of eighth notes with a slur and a fermata. Dynamics include *pp* and *p*. Fingerings are indicated as 7=8, 3=2, and 5=4. The word "Loco" is written above a section of eighth notes. The bass staff contains a series of chords, some with a slur and a fermata. A circled "8" is written to the left of the first measure.

Handwritten musical score for the second system. It consists of two staves: a treble clef staff on top and a bass clef staff on the bottom. The treble staff features a long, flowing melodic line with many notes, some with slurs and a fermata. Dynamics include *ppp* and *p*. The word "Loco" is written above a section of eighth notes. Fingerings are indicated as 5=4 and 3=2. The bass staff contains a series of chords, some with a slur and a fermata. A circled "8" is written below the bass staff.

9

$\downarrow = 64$

ppp

9:8

5:4

7:8

(7)

(7)

(ppp)

10

ppp

mfz

(PED) (1/2R)

(1/2R)

(1/2) e sim...

5:4

7:8

5:4

7:8

5:4

mf

11

$\downarrow = 48$

ppp

5:6

3:2

9:8

5:4

3:2

5:6

5:4

9:8

9:8

9:8

5:4

3:2

5:4

3:2

5:4

7:8

5:4

3:2

5:4

(PED)

RALL.

$\downarrow = 96$

12

Handwritten musical score for system 12, measures 1-12. The score is written in treble clef with a key signature of two sharps (F# and C#). It features a melodic line with slurs and a piano accompaniment. Dynamics include *mf* and *p*. A *RALL.* (Ritardando) marking is present at the top right. A bracket below the first measure is labeled  $(1) \frac{1}{2} \text{p}$ . The system ends with a double bar line.

$\downarrow = 90$

Handwritten musical score for system 12, measures 13-24. The score is written in treble clef with a key signature of two sharps. It features a melodic line with slurs and a piano accompaniment. Dynamics include *pppp*. A *UC* (Una Corda) marking is present in the first measure. A *PED (PULL)* marking is present below the piano part. The system ends with a double bar line.

$\downarrow = 60$  WITH SUBTLE RUBATO

(SHARPLY)

13

Handwritten musical score for system 13, measures 1-12. The score is written in treble clef with a key signature of two sharps. It features a melodic line with slurs and a piano accompaniment. Dynamics include *ppp* and *pp*. A *(LACO)* marking is present in the first measure. A *PED* marking is present below the piano part. The system ends with a double bar line.



(SAME TEMPO) (sim) MARC. IN p

14

ppp (AS SMOOTHLY AS POSSIBLE)

(PED)

POCO RIT. (CLOUDY)

mfz

mfz p

(ppp)

(PED)

mfz

mfz

mfz

(ppp)

p

3-2

mfz

(VERY SHORT)

(PED)

3-2

RALL.

$\text{♩} = 136$  LEGATO, FLOWING - DYING AWAY

15

ff

dim...

mf

(p)

(PEDAL FOR LEGATO)

p

pppp

(VC)

(3P)

(PED)

16/17

$b = 60$

Handwritten musical score for measures 16 and 17. The score is written on two staves (treble and bass clef). It features complex rhythmic patterns, including triplets and sixteenth notes. Dynamic markings include *pp*, *p*, *mf*, and *mfz*. There are also performance instructions like (PED) and (bb). The tempo is marked as  $b = 60$ .

Handwritten musical score for measures 18 and 19. The score is written on two staves (treble and bass clef). It features complex rhythmic patterns, including triplets and sixteenth notes. Dynamic markings include *p*, *mf*, *ppp*, and *(poco) f*. There are also performance instructions like (poco) and (PED).

18

*pp*

*f*

*mf*

*p*

*SLOWER*

7:8

5:4

(NO PAUSE)

(PED.)

19

Handwritten musical score for the first system, measures 1-8. The score is written on two staves. The upper staff begins with a treble clef and a common time signature. The lower staff begins with a bass clef and a common time signature. The music consists of complex rhythmic patterns with various note values and rests. Above the staves, there are several horizontal lines with brackets indicating specific rhythmic intervals:  $5=4$ ,  $9=8$ ,  $9=8$ , and  $7=6$ . Dynamic markings include *p* (piano), *mf* (*poco*) (mezzo-forte, a little), and *ppp* (*ped*) (pianissimo, with pedal). A large slur covers the entire system, with a *p* marking at the beginning and an *mf* (*poco*) marking towards the end. A *7* is written below the first measure of the lower staff, and another *7* is written below the last measure of the lower staff. A  $3=2$  interval is marked below the lower staff in the middle. The system ends with a double bar line and an arrow pointing to the right.

Handwritten musical score for the second system, measures 9-16. The score is written on two staves. The upper staff begins with a treble clef and a common time signature. The lower staff begins with a bass clef and a common time signature. The music continues with complex rhythmic patterns. Above the staves, there are several horizontal lines with brackets indicating specific rhythmic intervals:  $7=8$ ,  $5=4$ ,  $5=6$ , and  $5=4$ . Dynamic markings include *pp* (pianissimo), *mf* (*loca*) (mezzo-forte, a little), and *ppp* (*ped*) (pianissimo, with pedal). A large slur covers the entire system, with a *pp* marking at the beginning and an *mf* (*loca*) marking towards the end. A *7* is written below the first measure of the lower staff, and another *7* is written below the last measure of the lower staff. A  $3=2$  interval is marked below the lower staff in the middle. The system ends with a double bar line.

$\downarrow = 76$

20

Handwritten musical score for system 20, measures 1-10. The score is written on two staves. The upper staff contains complex rhythmic patterns with various time signatures: 3, 7:5, 5:4, 3:2, 5:4, 5:4, and 5:4. Dynamic markings include *pp*, *mf*, and *pp*. The lower staff contains a bass line with dynamic markings *mf*, *pp*, and *pp*. Pedal markings include *L(PED)* and *mf*. There are also some handwritten notes like *mf* and *pp* with arrows indicating dynamics.

Handwritten musical score for system 20, measures 11-20. The score continues on two staves. It includes a section marked *(Loco)* in the upper staff. Dynamic markings include *pp*, *mf*, and *pp*. Pedal markings include *(PED)* and *pp*. There are also some handwritten notes like *mf* and *pp* with arrows. The system ends with the instruction *(ABRUPT. RELEASE)*.

$\downarrow = 96$

21

Handwritten musical score for system 21, measures 1-10. The score is written on two staves. The upper staff features a section marked *RALL.* with a large slur over it. Dynamic markings include *ppp* and *pppp*. The lower staff contains a bass line with dynamic markings *ppp* and *pppp*. Pedal markings include *(PED)* and *ppp*. There are also some handwritten notes like *ppp* and *pppp* with arrows. The system ends with the instruction *(PED. FULL)*.

$\downarrow = 76$

Handwritten musical score for the first system, measures 1-8. It features two staves with piano parts and a circled '8' below the left staff. The music is in a key with one flat and a 5/4 time signature. Dynamics include pppp and ppp. Pedal markings include (PED) and (FULL). A circled 'UC' is at the end of the system.

$\downarrow = 60$

Handwritten musical score for the second system, measures 9-16. It features two staves with piano parts and a circled '8' below the left staff. The music is in a key with one flat and a 5/4 time signature. Dynamics include p and ppp. Pedal markings include (PED). A circled 'UC' is at the beginning of the system.

22

Handwritten musical score for the third system, measures 17-24. It features two staves with piano parts and a circled '8' below the left staff. The music is in a key with one flat and a 5/4 time signature. Dynamics include ppp and pppp. Pedal markings include (PED). A circled 'UC' is at the end of the system. The text "(NO PAUSE)" is written on the right side.

$\text{♩} = 104$  MOLTO LEGATO

164

23

Handwritten musical score for measures 164-172. The score is written on three staves: Treble Clef (top), Treble Clef (middle), and Bass Clef (bottom). The music is in a complex, multi-measure rhythmic structure with various time signatures indicated by brackets above the notes: 9:8, 5:4, 5, 3:2, 7:8-5:4, 5:4, 3:2, 9:8, 5:4, 5:4, 5:4, 3:2, 5:4, 5:4, 3:2, 5:4, 5:4, 3:2. Dynamics include *pp*, *mf*, and *ppp*. A fermata is present over the final note of measure 172. A pedal point is indicated by a horizontal line with a vertical tick at the beginning of the piece and the label "(PED)" below the bass staff.

Handwritten musical score for measures 173-181. The score is written on three staves: Treble Clef (top), Treble Clef (middle), and Bass Clef (bottom). The music continues with complex rhythmic patterns and time signatures: 5:4, 9:8, 3:2, 5:4, 5:6, 3:2, 5:4, 3:2, 7:8, 5:4, 3:2, 5:4, 3:2, 5:4, 3:2. Dynamics include *ppp*, *pp*, and *ppp*. A fermata is present over the final note of measure 181. The piece concludes with the instruction "(ATTACCA 24)" written in the right margin. A pedal point is indicated by a horizontal line with a vertical tick at the beginning of the piece and the label "(PED)" below the bass staff.



# MISTILY - AS BEFORE

ACCELL.

RALL.

24

♩ = 40      9:8      ♩ = 60      9:8      (SIM.) LOCO      9:8      ♩ = 48

pppp      pp      (pppp)

C# B# A#

7:8      7:8      7:8 (HALF-RELEASE)

ACCELL.      RALL.

24

♩ = 40      ♩ = 60      ♩ = 48

9:8      9:8      9:8

(SIM.) LOCO

pppp      pp      (pppp)

C# B# A#

7:8      7:8      7:8 (HALF-RELEASE)

ACCELL.      RALL.

♩ = 40      ♩ = 60      ♩ = 48

9:8      9:8      9:8

(SIM.) LOCO

pppp      pp      (pppp)

C# B# A#

7:8      7:8      7:8 (HALF-RELEASE)

ACCELL.      RALL.

♩ = 57      9:8      ♩ = 48 (BEGIN ACCELL.)      ♩ = 96

9:8      9:8      9:8

pppp      pp      pppp      ppp

(PED.)

(FULL RELEASE)

D# C# B#

♩ = 57      ♩ = 48      ♩ = 96

9:8      9:8      9:8

pppp      pp      pppp      ppp

(PED.)

(FULL RELEASE)

D# C# B#

$\text{♩} = 96$

25-27

$\text{♩} = 66$  (SOTTO VOCE)  $\text{♩} = 3/2$

Handwritten musical score for measures 25-27. The piano part is written in two staves (treble and bass clef). The tempo is  $\text{♩} = 96$ . Dynamics include *mf* and *ppp*. The vocal part (SOTTO VOCE) is written in a single staff with a tempo of  $\text{♩} = 66$ . It includes a *pp* dynamic and performance instructions: "(PED) (FULL)".

Continuation of the musical score. This section contains detailed rhythmic markings such as "3:2", "5:4", and "7:8". Dynamics include *pp* and *f*. There are also performance instructions like "(Lento)", "(ped)", and "(ch)".

Final section of the musical score. It features complex rhythmic patterns with markings like "5:4", "9:8", and "7:8". Dynamics include *pp* and *pppp*. There are also performance instructions like "(PED)".

(QUASI-ECHO)

28

$\downarrow = 96$

(Loco)

(PED) (FULL)

VC

(8 BEATS)

(ATTACCA 29)

VC (PED)

$\downarrow = 116$  CRISPLY, DISTANT

29

pp

mf

pp

(Loco)

VC

30

10"

$\text{♩} = 60$  SMOOTHLY, WHISPERED

168

31

Handwritten musical score for the first system, measures 168-171. The score is written on two staves (treble and bass clef). It features a complex rhythmic pattern with many sixteenth notes and rests. Dynamic markings include *ppp* at the beginning and *pp* later in the system. A large slur covers the entire system. A tempo marking  $\text{♩} = 60$  is written below the first staff. A dynamic marking  $\frac{1}{2}p$  with an arrow pointing right is located below the first staff.

Handwritten musical score for the second system, measures 172-175. The score is written on two staves. It continues the complex rhythmic pattern. Dynamic markings include *mf* and *pp*. A *Loco* marking is present at the end of the system. A large slur covers the entire system. A dynamic marking  $\frac{1}{2}p$  with an arrow pointing right is located below the first staff.

Handwritten musical score for the third system, measures 176-179. The score is written on two staves. It continues the complex rhythmic pattern. Dynamic markings include *ppp*. A large slur covers the entire system. A dynamic marking  $\frac{1}{2}p$  with an arrow pointing right is located below the first staff. At the end of the system, there is a thick vertical bar and the text "(NO PAUSE)".

(CATCH MOST OF THE RESONANCE)

SLIGHT  
ACCELL.

♩ = 48      9:8      ♩ = 88

32  
33

♩ = 96

3A

♩ = 60

170

$\downarrow = 55$  RALL.

ACCELL.

35

Handwritten musical score for the first system, measures 170-175. It features a treble and bass clef staff with complex rhythmic patterns. Above the treble staff, there are three measures of a 9:8 ratio. Above the bass staff, there are three measures of a 7:8 ratio. Dynamics include ppp and pp. A fermata is present over the first measure of the treble staff.

(PED.)

(HALF-RELEASE)

SLIGHT ACCELL.

( $\downarrow = 52$ )

$\downarrow = 53$

$\downarrow = 48$

Handwritten musical score for the second system, measures 176-181. It continues the treble and bass clef staff. Above the treble staff, there are three measures of a 9:8 ratio. Above the bass staff, there are three measures of a 7:8 ratio. Dynamics include ppp. A fermata is present over the last measure of the treble staff.

(PED.)

(A#)

\*

$\downarrow = 52$

(COUNT THROUGH)

(ATTACCA 36)

Musical score for the first system, measures 1-36. It features a grand staff with treble and bass clefs. The key signature has one sharp (F#). The tempo is marked as  $\downarrow = 52$ . The dynamics are *pppp*. There are handwritten annotations: a circled 'VC' and '(PED)' at the bottom left, and a circled '7' at the end of the system. A bracket labeled '5:4' spans across measures 15-18. The system ends with a double bar line and a circled '7'.

$b = 48$

36

Musical score for the second system, measures 37-72. It features a grand staff with treble and bass clefs. The key signature has one sharp (F#). The tempo is marked as  $b = 48$ . The dynamics are *pp* and *mf (poco)*. There are handwritten annotations: a circled 'VC' and '(PED)' at the bottom left, and a circled '8' at the end of the system. A bracket labeled '7:8' spans across measures 45-50. Another bracket labeled '7:8' spans across measures 55-60. A bracket labeled '5:4' spans across measures 65-70. The system ends with a double bar line and a circled '8'.

Musical score for the third system, measures 73-108. It features a grand staff with treble and bass clefs. The key signature has one sharp (F#). The dynamics are *pp* and *mf (poco)*. There are handwritten annotations: '(Loco)' at the beginning, a circled 'VC' and '(PED)' at the bottom left, and a circled '9' at the end of the system. A bracket labeled '9:8' spans across measures 75-80. Another bracket labeled '7:8' spans across measures 85-90. A bracket labeled '5:4' spans across measures 95-100. A bracket labeled '9:8' spans across measures 105-110. The system ends with a double bar line and a circled '9'.

$\text{♩} = 94$  LEGATO  
CANTABILE

172

37

(PEDAL FOR LEGATO)

(SLIGHTLY DETACHED)

$\text{♩} = 84$   $7.$

3P



38

Handwritten musical score for measures 38 and 39. Measure 38 features complex rhythmic patterns with 3:2 and 5:4 time signatures, dynamic markings like ppp and p, and various accidentals. Measure 39 shows a continuation of these patterns with a 3:2 time signature and a 5:4 time signature, ending with a fermata and a crescendo line.

39

Handwritten musical score for measures 39 and 40. Measure 39 continues the complex rhythmic patterns with a 3:2 time signature and a 5:4 time signature, ending with a fermata and a crescendo line. Measure 40 features a section marked "EXPLOSIVELY!! WHISPERED" with a tempo marking of quarter note = 56, and includes a "x5" multiplier and dynamic markings like pppp and (PED).

40

Handwritten musical score for measures 40 and 41. Measure 40 features a section marked "EXPLOSIVELY!! WHISPERED" with a tempo marking of quarter note = 56, and includes a "x5" multiplier and dynamic markings like pppp and (PED). Measure 41 features a section marked "p" with a 7:8 time signature and a 5:4 time signature, ending with a fermata and a crescendo line.

Handwritten musical score for the first system. It consists of a piano staff (top) and a grand staff (middle). The piano staff begins with a treble clef and a key signature of one sharp (F#). It contains several notes with dynamic markings: *ppp* and *mp*. A bracket labeled *5=A* spans two notes. The grand staff contains two staves, with the lower staff starting with a bass clef and a key signature of one sharp. It features notes with a dynamic marking of *Lpppp*. Below the grand staff is a dashed line with a circled *UC* and an arrow pointing right. To the left of this line is the instruction *(PED)*.

Handwritten musical score for the second system. It consists of a piano staff (top) and a grand staff (middle). The piano staff begins with a treble clef and a key signature of one sharp. It contains notes with dynamic markings *f=8*. The grand staff contains two staves, with the lower staff starting with a bass clef and a key signature of one sharp. It features notes with dynamic markings *f=8*. Below the grand staff is a dashed line with a circled *UC* and an arrow pointing right. To the left of this line is the instruction *(PED)*. At the end of the system, there is a thick vertical bar followed by the instruction *(ATTACCA 41)*.

41

Handwritten musical score for measure 41. The score is written on a grand staff (treble and bass clefs). Above the staff, there are tempo markings:  $\text{♩} = 48$  and  $\text{♩} = 52$  (LACO). There are also annotations for  $9:8$  ratios and  $(SIM)$ . Below the staff, there are annotations for  $7:8$  ratios and  $(PED.)$ . The music consists of complex rhythmic patterns with many beamed notes and rests.

42

Handwritten musical score for measure 42. The score is written on a grand staff (treble and bass clefs). Above the staff, there are tempo markings:  $\text{♩} = 53$ . There are annotations for  $5:4$  ratios and  $(ACCELL)$ . Below the staff, there are annotations for  $7:8$ ,  $5:4$ ,  $3:2$ , and  $(PED.)$ . The music includes dynamic markings like  $mf$ ,  $p$ ,  $f$ , and  $pp$ . The score ends with a double bar line and a repeat sign.

(♩=53)

43

Musical score for measures 43-47. The system consists of a grand staff with treble and bass clefs. The right hand contains a melodic line with various intervals and dynamics. The left hand provides harmonic support with chords and a pedal point. Above the staff, time signatures are indicated: 7:8, 3:2, 5:4, 3:2, 7:8, and 7:8. Dynamics include *mf*, *pp*, and *pp*. Pedal markings (PED) are shown below the bass staff. A circled '3p' is located at the bottom left of the system.

44

Musical score for measures 48-52. The system consists of a grand staff. The right hand features a melodic line with a large slur over measures 49-52. The left hand has a steady accompaniment. Above the staff, a 5:4 time signature is marked. Dynamics include *p* and *pp*. Pedal markings (PED) are present. A circled '3p' is at the bottom left.

Musical score for measures 53-57. The system consists of a grand staff. The right hand has a melodic line with a large slur over measures 53-56. The left hand accompaniment includes chords and a pedal point. Above the staff, 5:4 time signatures are marked. Dynamics include *ppp*. Pedal markings (PED) are shown. A circled '3p' is at the bottom left, and a circled '(B4)' is at the bottom right.

45

$\downarrow = 50$

$9:8$

$\downarrow = 48$  (NO ACCELL.)

$9:8$

$7:8$

$7:8$

(PED)

$9:8$

$9:8$

$7:8$

$7:8$

(PED)

$\downarrow = 48$

$9:8$

$9:8$

$5:4$

$5:4$

(ATTACCA 46)

(PED)

POCO RALL.

$\downarrow = 86$

178

46

Handwritten musical score for measures 178-185. The system includes a treble clef staff with notes and rests, a bass clef staff with notes and rests, and a pedal line below. The tempo is marked  $\downarrow = 86$  and  $\downarrow = 80$ . Rhythmic markings include  $3:2$ ,  $5:4$ , and  $5:6$ . Dynamics include  $mf$ ,  $pp$ , and  $ppp$ . Pedal markings include  $(PED)$  and  $8$ . Chord progressions are indicated as  $F G B \flat B \flat D \flat E \flat$  and  $E \flat F G \# B C \#$ . A  $3:2$  ratio is also marked in the lower system.

$\downarrow = 76$

(PED)

Handwritten musical score for measures 186-193. The system includes a treble clef staff with notes and rests, a bass clef staff with notes and rests, and a pedal line below. The tempo is marked  $\downarrow = 76$  and  $\downarrow = 69$ . Rhythmic markings include  $5:6$ ,  $3:2$ , and  $5:4$ . Dynamics include  $ppp$ . Pedal markings include  $8$ . A  $3:2$  ratio is marked in the lower system.

47

Handwritten musical score for measures 194-201. The system includes a treble clef staff with notes and rests, a bass clef staff with notes and rests, and a pedal line below. The tempo is marked  $\downarrow = 86$ . Dynamics include  $ppp$ . Pedal markings include  $8$ . A  $3:2$  ratio is marked in the lower system.

(POCO ACCEL.)

Handwritten musical score for the first system. It features a treble and bass clef staff with complex rhythmic notation. Above the staff, there are tempo markings:  $\downarrow = 48$  and  $\downarrow = 80$ . A bracket labeled "(LACO)" spans a section of the music with a "9=8" marking. Other markings include "8", "5:4", and "7=8". A vertical bar line is present. Below the staff, there is a dashed line with a circled "3p" and a right-pointing arrow. A "PED" marking is also present.

48/9

Handwritten musical score for the second system. It features a treble and bass clef staff. Above the staff, there is a tempo marking "(POCO RALL)". A bracket above the staff is labeled "5:4". Below the staff, there are markings for dynamics: "pp", "p", "mf", and "pp". A circled "3p" is located at the bottom left of the system. The system ends with a double bar line.

1 JANUARY 2015-  
2:30 AM 14 APRIL 2016